

USER MANUAL

0871LH1 Freezing Rain Sensor



Issued: 27.1.14

Copyright © 2007-2012 Campbell Scientific (Canada) Corp.
Printed under licence by Campbell Scientific Ltd.

Guarantee

This equipment is guaranteed against defects in materials and workmanship. This guarantee applies for twelve months from date of delivery. We will repair or replace products which prove to be defective during the guarantee period provided they are returned to us prepaid. The guarantee will not apply to:

- Equipment which has been modified or altered in any way without the written permission of Campbell Scientific
- Batteries
- Any product which has been subjected to misuse, neglect, acts of God or damage in transit.

Campbell Scientific will return guaranteed equipment by surface carrier prepaid. Campbell Scientific will not reimburse the claimant for costs incurred in removing and/or reinstalling equipment. This guarantee and the Company's obligation thereunder is in lieu of all other guarantees, expressed or implied, including those of suitability and fitness for a particular purpose. Campbell Scientific is not liable for consequential damage.

Please inform us before returning equipment and obtain a Repair Reference Number whether the repair is under guarantee or not. Please state the faults as clearly as possible, and if the product is out of the guarantee period it should be accompanied by a purchase order. Quotations for repairs can be given on request. It is the policy of Campbell Scientific to protect the health of its employees and provide a safe working environment, in support of this policy a "Declaration of Hazardous Material and Decontamination" form will be issued for completion.

When returning equipment, the Repair Reference Number must be clearly marked on the outside of the package. Complete the "Declaration of Hazardous Material and Decontamination" form and ensure a completed copy is returned with your goods. Please note your Repair may not be processed if you do not include a copy of this form and Campbell Scientific Ltd reserves the right to return goods at the customers' expense.

Note that goods sent air freight are subject to Customs clearance fees which Campbell Scientific will charge to customers. In many cases, these charges are greater than the cost of the repair.



Campbell Scientific Ltd,
Campbell Park, 80 Hathern Road,
Shepshed, Loughborough, LE12 9GX, UK
Tel: +44 (0) 1509 601141
Fax: +44 (0) 1509 601091

Email: support@campbellsci.co.uk
www.campbellsci.co.uk

PLEASE READ FIRST

About this manual

Please note that this manual was originally produced by Campbell Scientific Inc. primarily for the North American market. Some spellings, weights and measures may reflect this origin.

Some useful conversion factors:

Area: 1 in ² (square inch) = 645 mm ²	Mass: 1 oz. (ounce) = 28.35 g 1 lb (pound weight) = 0.454 kg
Length: 1 in. (inch) = 25.4 mm 1 ft (foot) = 304.8 mm 1 yard = 0.914 m 1 mile = 1.609 km	Pressure: 1 psi (lb/in ²) = 68.95 mb
	Volume: 1 UK pint = 568.3 ml 1 UK gallon = 4.546 litres 1 US gallon = 3.785 litres

In addition, while most of the information in the manual is correct for all countries, certain information is specific to the North American market and so may not be applicable to European users.

Differences include the U.S standard external power supply details where some information (for example the AC transformer input voltage) will not be applicable for British/European use. *Please note, however, that when a power supply adapter is ordered it will be suitable for use in your country.*

Reference to some radio transmitters, digital cell phones and aerials may also not be applicable according to your locality.

Some brackets, shields and enclosure options, including wiring, are not sold as standard items in the European market; in some cases alternatives are offered. Details of the alternatives will be covered in separate manuals.

Part numbers prefixed with a “#” symbol are special order parts for use with non-EU variants or for special installations. Please quote the full part number with the # when ordering.

Recycling information



At the end of this product's life it should not be put in commercial or domestic refuse but sent for recycling. Any batteries contained within the product or used during the products life should be removed from the product and also be sent to an appropriate recycling facility.

Campbell Scientific Ltd can advise on the recycling of the equipment and in some cases arrange collection and the correct disposal of it, although charges may apply for some items or territories.

For further advice or support, please contact Campbell Scientific Ltd, or your local agent.



Campbell Scientific Ltd, Campbell Park, 80 Hathern Road, Shepshed, Loughborough, LE12 9GX, UK
Tel: +44 (0) 1509 601141 Fax: +44 (0) 1509 601091
Email: support@campbellsci.co.uk
www.campbellsci.co.uk

Contents

PDF viewers note: These page numbers refer to the printed version of this document. Use the Adobe Acrobat® bookmarks tab for links to specific sections.

1. Purpose	1
2. General	1
3. Detailed Principle of Operation	1
4. Specifications	3
5. Physical Description	4
6. Temperature Considerations	5
7. Power Interruptions	5
8. Mounting Considerations	6
9. Wiring	7
9.1 0871LH1CBL-L Wiring for Discrete Output	7
9.2 0871LH1CBL-L Wiring for RS422 Output	8
10. Program Examples	9
10.1 CR1000 Example – Discrete Outputs	9
10.2 CR23X Example – Discrete Outputs	11
10.3 CR1000 Example – RS422 Outputs	12

Figures

1. MSO Circuit Sectional View	2
2. MSO Circuit Schematic	3
3. Ice detector	5
4. Mounting	6
5. General Hook-up Diagram	8
B1. Functional Block Diagram	B-1

Tables

1. 0871LH1 Connector Pinout	4
2. Datalogger Connections	7
3. Power Connections to Terminal Expander	7
4. Datalogger Connections	8
5. Power Connections to Terminal Expander	9
6. SC110 Connections	9

A-1. BIT Information..... A-2
A-2. Serial String Format..... A-5
B-1. 0871LH1 Ice Detector Qualification Capabilities.....B-4
B-2. Input/Output Pin DesignationsB-5

Appendices

A. RS-422 Output Format A-1
B. Freezing Rain Sensor B-1

0871LH1 Freezing Rain Sensor

1. Purpose

This document provides detailed information about the Rosemount Aerospace model 0871LH1 Freezing Rain Sensor for use in ground-based meteorological applications. Topics covered include requirements, qualification categories and methodology, and detailed design information.

2. General

The Rosemount Aerospace 0871LH1 Freezing Rain Sensor is a one-piece unit that detects the presence of icing condition. Twenty-four volts DC input power is provided to the freezing rain sensor. The freezing rain sensor outputs include ice detection indication and fault status indication. These outputs are provided through an RS-422 interface and discrete outputs. One freezing rain sensor is used on each station and provides the primary means of ice detection. The ice signal is used to indicate to the operator that an icing condition exists so that appropriate actions can be taken.

3. Detailed Principle of Operation

The freezing rain sensor uses an ultrasonically axially vibrating probe to detect the presence of icing conditions. The sensing probe is a nickel alloy tube mounted in the strut at its midpoint (node) with one inch exposed to the elements. This tube exhibits magnetostrictive properties: it expands and contracts under the influence of a variable magnetic field. A magnet mounted inside the strut and modulated by a drive coil surrounding the lower half of the tube provides the magnetic field.

A magnetostrictive oscillator (MSO) circuit is created with the above components and the addition of a pickup coil and an electronic comparator. The ultrasonic axial movement of the tube resulting from the activation of the drive coil causes a current to be induced in the pickup coil. The current from the pickup coil drives the comparator that, in turn, provides the signal for the drive coil.

The oscillation frequency of the circuit is determined by the natural resonant frequency of the sensor tube, which is tuned to 40 kHz. With the start of an icing event, ice collects on the sensing probe. The added mass of accreted ice causes the frequency of the sensing probe to decrease in accordance with the laws of classical mechanics. A 0.5 mm (0.020") thickness of ice on the probe causes the operating frequency of the probe to decrease by approximately 130 Hz. The freezing rain sensor onboard software monitors the probe frequency, detects and annunciates any frequency decrease. At the same time, the internal probe heater power is applied until the frequency rises to a predetermined set point plus an additional delay factor to assure complete de-icing.

Once de-iced, the sensing probe cools within a few seconds and is ready to sense ice formation again. When ice forms on the sensing probe again to the point where the MSO frequency decreases by 130 Hz, the sensor de-ices itself again. This cyclic process is repeated as long as the freezing rain sensor remains in an icing environment. The ice signal activates at 0.5 mm ice accretion and stays on for 60 seconds after the end of the icing encounter. Specifically, when the output is activated, a 60-second timer is started. Each time 0.5 mm forms on the probe, the 60-second counter is reset. In effect, the output stays on for 60 seconds after the beginning of the “last” icing encounter.

The Status output indicates whether the freezing rain sensor is functioning correctly using tests that are described in more detail in following sections of this document.

**Ultrasonic Vibrating Probe
40KHz Nominal**

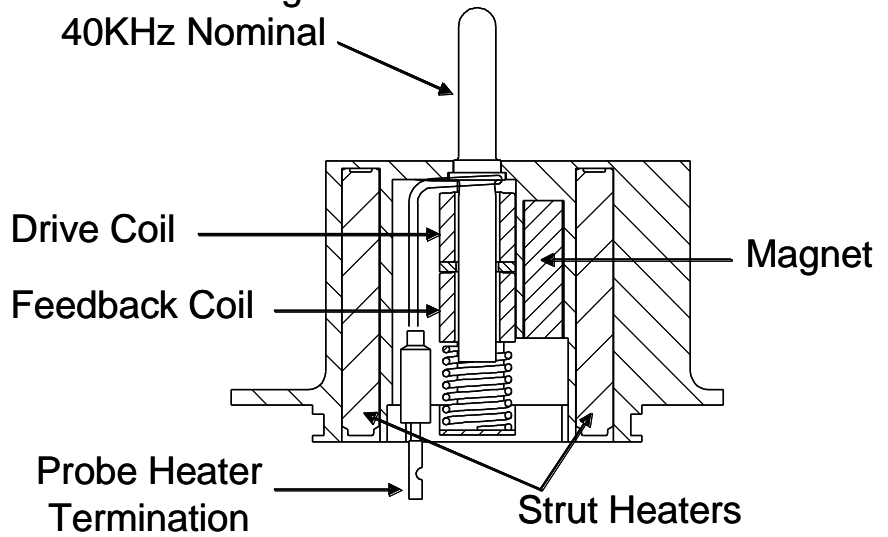

Figure 1 MSO Circuit Sectional View

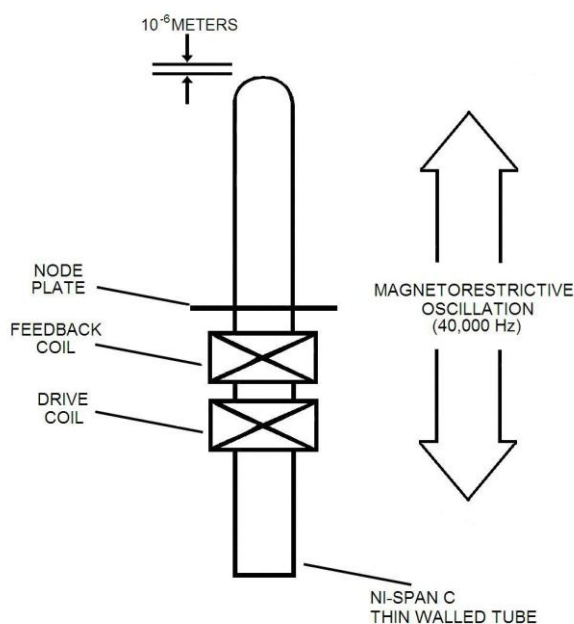

Figure 2 MSO Circuit Schematic

4. Specifications

Power Supply

Operating Voltage:	18 – 29.5 VDC
Power Draw:	5W max at 24 VDC (sensing mode) 27W max at 24 VDC (deicing mode)

Temperature

Operating:	-55°C to +71°C
Storage:	-65°C to +90°C

Communication Outputs

Discrete Outputs:	for Icing and Status No Icing – Open, Icing – Ground Status OK – Ground, Status Failure – Open
-------------------	--

RS-422:	Hexidecimal 24-byte string (ASCII format) 9600 Baud (1 Start Bit, 8 Data Bits, No Parity, 1 Stop Bit)
---------	--

RS422 Outputs:	for Icing and Status No Icing – 0, Icing – 1 Status OK – 0, Status Failure – 1
----------------	--

Icing Signal Period:	60 second activation from start of icing measurement (Discrete or RS-422 outputs)
----------------------	--

Connector Pinout

Table 1. 0871LH1 Connector Pinout	
Connector Pin	Signal Description
A	24VDC
B	24VDC Return
C	Case Ground
D	RS-422 High
E	RS-422 Low
F	Ice
G	Status

Mating Connector: MS27473T10B99SN

De-icing Control Automatically triggered with accumulation of 0.5mm of ice on probe
Max heating time – 25 seconds

5. Physical Description

The freezing rain sensor is an integrated unit containing both the sensor and processing electronics. It contains a 7.35 cm (2.9") square faceplate for mounting to the 0871LH1MNT and a 7.28 cm (2.86") diameter housing containing the processing electronics. The maximum weight of a unit is 318 grams (0.7 lbs).

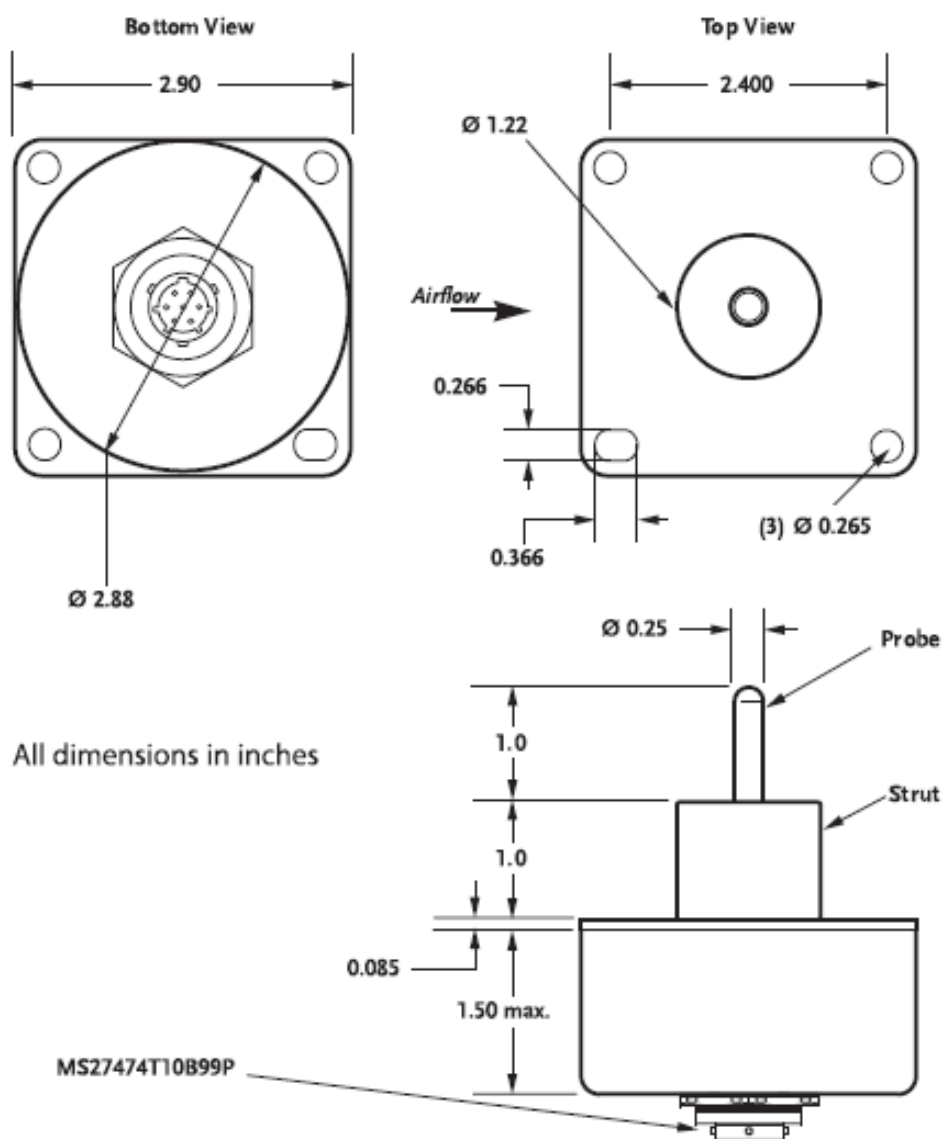

Figure 3 Ice Detector

6. Temperature Considerations

In the case of unit malfunction causing strut heater lock-on, the probe temperature can exceed 204.4°C. Maintenance personnel should exercise caution when servicing the unit.

7. Power Interruptions

The freezing rain sensor is qualified to DO-160C power input category Z. The unit will remember status through a 200 ms power interruption, but the output string will cease during the interruption.

The freezing rain sensor uses a power fail monitor to verify the supply voltage. If a power fault is detected the freezing rain sensor is halted with a failure indication on the STATUS discrete output.

8. Mounting Considerations



Figure 4 Mounting (part #0871LH1 MNT)

The freezing rain sensor should be mounted to a sturdy crossarm located away from buildings or other obstacles that could shadow the sensing element from freezing rain. The sensor should be installed so that the sensing probe is a minimum of 92 cm (36") above the ground.

1. Remove the protective tube from strut.
2. Attach the freezing rain sensor to the mounting bracket using the supplied $\frac{1}{4}$ - 20 screws and lock washers. Position the freezing rain sensor on the mounting pole with the sensing probe pointing upward, with the bracket inclined at a 20° - 30° angle above horizontal to ensure proper drainage of melted ice.
3. Attach to a vertical or horizontal pipe using the supplied V bolts, nuts and washers. NOTE: The sensor should be mounted so as to be oriented into the prevailing wind.
4. Connect cable to 0871LH1 connector and secure cable to bracket with cable ties.
5. Remove shipping cover and protective cap prior to powering on the unit.

9. Wiring

The wiring of the 0871LH1 will depend on the required communication outputs of your application. If you require the use of the discrete outputs of the 0871LH1, then refer to Section 9.1. If you require the use of the RS-422 output, then refer to Section 9.2.

NOTE Please contact a Certified Electrician to properly install the C2673 power supply. All electrical connections and housings must be installed by a Certified Electrician.

9.1 0871LH1CBL-L Wiring for Discrete Output

Description	Pin	Colour	CR3000/CR1000	CR10X/CR510
Ice	F	Blue	C1	C1
Status	G	Yellow	C2	C2
RS422 A	D	White	N/C	N/C
RS422 B	E	Brown	N/C	N/C
Power Reference	B	Black	G	G
Case GND	C	Green	G	G
5V Power		Purple	5V	5V
Shield		Clear	G	G

WARNING The 5VDC connection must be made to avoid damage to the 0871LH1.

WARNING Isolate wires that are not connected as they will cause problems if shorted to ground.

Description	Pin	Colour	Connection
24 VDC	A	Red	V+
24VDC Return	B	Black	V-

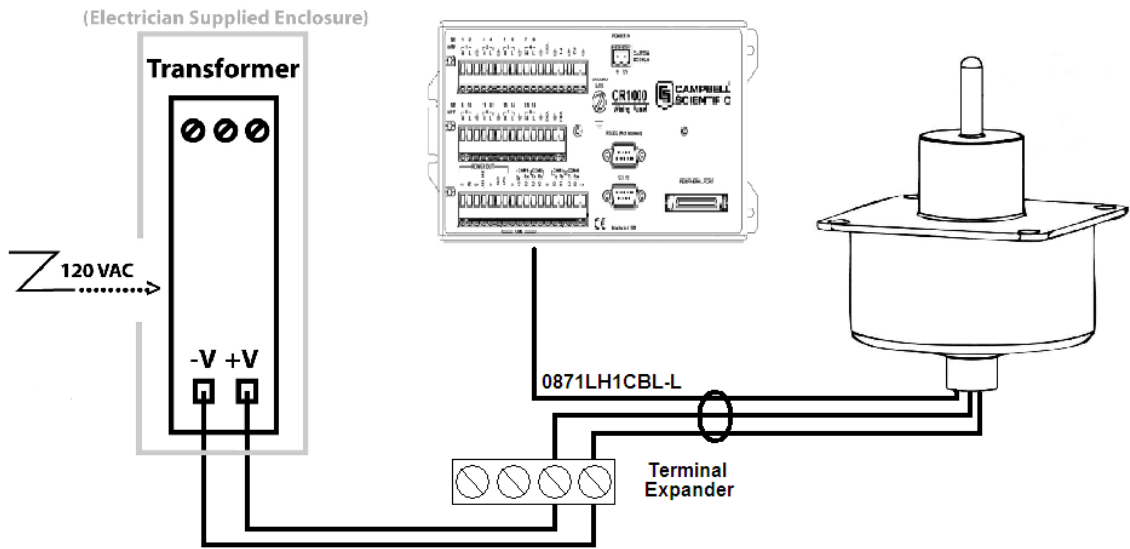

Figure 5 General Hook-up Diagram

9.2 0871LH1CBL-L Wiring for RS422 Output

NOTE The MD485 Multidrop Interface, the L15966 Wall Charger and the SC110 Interface Cable are required to measure the RS422 output on a CR1000 or CR3000.

NOTE The MD485 Multidrop Interface must be configured for Active Ports | RS232 and RS485, RS232 Baud Rate | 9600, and RS485 Baud Rate | 9600. Refer to the MD485 Manual for configuration instructions.

Table 4. Datalogger Connections				
Description	Pin	Colour	Sensor – MD485	Sensor – CR1000/CR3000
Ice	F	Blue	N/C	N/C
Status	G	Yellow	N/C	N/C
RS422 A	D	White	RS485 A	N/C
RS422 B	E	Brown	RS485 B	N/C
Power Reference	B	Black	N/C	G
Case GND	C	Green	N/C	G
5V Power		Purple	N/C	G
Shield		Clear	N/C	G

NOTE If the application requires the monitoring of the discrete outputs the 5Vdc connection must be made.

WARNING **Isolate wires that are not connected as they may cause problems if shorted to ground.**

Table 5. Power Connections to Terminal Expander

Description	Pin	Colour	Connection
24VDC	A	Red	V+
24VDC Return	B	Black	V-

Table 6. SC110 Connections

Description	Colour	MD485	CR1000/CR3000
DB9 Male Connector		RS-232 (to DTE)	N/C
CR1000 Tx	Brown	N/C	C3
CR1000 Rx	White	N/C	C4
CR1000 Gnd	Yellow	N/C	G
Shield	Clear	N/C	G

10. Program Examples

It is possible to collect icing information either by the discrete outputs of the 0871LH1, or the available RS422 output.

10.1 CR1000 Example – Discrete Outputs

Monitor the discrete outputs of the 0871LH1 for icing events and changes to the sensor status. Data tables are updated only after an icing event or status change occurs.

```

'Declare Public Variables
Public TimeCount
Public IceSignal 'ice signal: Open = no ice, Ground = ice
Public StatusSignal 'status signal: Ground = okay, Open = fault

'Define Data Tables
DataTable (Sensor_Status,True,-1)
  Sample (1,StatusSignal,FP2)
EndTable

DataTable (Ice_Condition,True,-1)
  Sample (1,IceSignal,FP2)
EndTable

'Main Program
BeginProg

'In order for the datalogger to receive data from the 0871LH1, 'ports 1 & 2 must be configured as inputs.
PortsConfig (&B11,&B00)
Scan (5,Sec,0,0)

'Start timer to corrdinate monitoring of ice signal output from sensor
TimeCount = Timer (1,Sec,0)

'During icing event the sensor cycles through a 60 second monitoring 'interval. When the first icing event occurs
'a 60 second counter is started in the sensor. Once the 60 seconds have pasted the sensor will determine
'if further icing has occurred. If yes, the sensor signals the icing event, heats the probe, and resets counter.
'If no, the sensor signals no ice and resets counter.
If TimeCount >= 61 Then

  'Record sensor outputs for icing and status. Based on scan rate.
  PortGet (IceSignal,1)
  PortGet (StatusSignal,2)

  'If a status fault is detected then the status code is stored to the Sensor Status data table.
  'Only fault status data is stored to the table.
  If StatusSignal = 1 Then
    CallTable Sensor_Status
  EndIf

  'If an icing event is detected then store the record to the Ice Condition data table.
  If IceSignal = 0 Then
    CallTable Ice_Condition
    'Reset the datalogger counter during icing events so that data is'coordinated with the sensors counter.
    Timer (1,Sec,3)
  EndIf
EndIf
NextScan
EndProg

```

10.2 CR23X Example – Discrete Outputs

```

;Set Timer input location
1: Timer (P26)
1: 3   Loc [ Timer ]

;Use Timer to monitor Control Ports 1 & 2 every 61 seconds
2: If (X<=>F) (P8g)
1: 3   X Loc [ Timer ]
2: 3   >=
3: 61   F
4: 30   Then Do

3: Set Port(s) (P20)
1: 9999 C8..C5 = nc/nc/nc/nc
2: 9988 C4..C1 = nc/nc/input/input

;Read the status of the ports and store to input locations for comparison.
4: Read Ports (P25)
1: 1   Mask (0..255)
2: 2   Loc [ IceStat ]

5: Read Ports (P25)
1: 2   Mask (0..255)
2: 1   Loc [ FaultStat ]

;Check to see if there is a fault in the sensor and output it to final storage.
6: If (X<=>F) (P8g)
1: 1   X Loc [ FaultStat ]
2: 1   =
3: 1   F
4: 30   Then Do

7: Do (P86)
1: 10   Set Output Flag High (Flag o)

8: Set Active Storage Area (P80)^3085
1: 1   Final Storage Area 1
2: 10   Array ID

9: Real Time (P77)^1712
1: 1220 Year,Day,Hour/Minute (midnight = 2400)

10: Sample (P70)^23951
1: 1   Repts
2: 1   Loc [ FaultStat ]

11: End (P95)

;Check to see if there is Ice on the sensor and output it to final storage.
12: If (X<=>F) (P8g)
1: 2   X Loc [ IceStat ]
2: 1   =
3: 0   F
4: 30   Then Do

13: Do (P86)
1: 10   Set Output Flag High (Flag o)

14: Set Active Storage Area (P80)^10755

```

```

1: 1   Final Storage Area 1
2: 20  Array ID

15: Real Time (P77)^8112
1: 1220 Year,Day,Hour/Minute (midnight = 2400)

16: Sample (P70)^5446
1: 1   Reps
2: 2   Loc [ IceStat ]

;if there is ice on the unit, start a looping sequence that ends only when ice is no longer detected.
17: Timer (P26)
1: 0   Reset Timer

18: End (P95)
19: End (P95)

```

10.3 CR1000 Example – RS422 Outputs

NOTE The MD485 Multidrop Interface, the L15966 Wall Charger and the SC110 Interface Cable are required to measure the RS422 output on a CR1000 or CR3000.

NOTE The MD485 Multidrop Interface must be configured for Active Ports | RS232 and RS485, RS232 Baud Rate | 9600, and RS485 Baud Rate | 9600. Refer to the MD485 Manual for configuration instructions.

```

'CR1000 Series Datalogger

'Declare Public Variables
Public PTemp, batt_volt
Public LH1_Byte_Count As Float
Public Read_LH1 As Boolean
Public Ice
Public Ice_mm

'Define the Comport for the o871LH1 here:
Const LH1_comport = Com2

*****
'Public Variables from o871LH1 Sensor via RS-422 Output
*****
Public LH1_Serial_Error As Boolean

'This is the decimal equivalent of Bytes 1 to 24 output by the o871LH1
Public LH1_Byte(24) As Long

'String is 1 - On or 0 - Off
Public LH1_Probe_Heater_State As String * 3

'String is 1 - Ice or 0 - No Ice

```

```

Public LH1_Ice_Output As String * 6

'String is 1 - Fail 0 - OK
Public LH1_Status_Output As String * 4

'String is 1 - Fail 0 - OK
'ERRSTAT1
Public LH1_ERR_MSO_TOO_HIGH As String * 4
Public LH1_ERR_MSO_TOO_LOW As String * 4
Public LH1_ERR_EEPROM As String * 4
Public LH1_ERR_RAM As String * 4
Public LH1_ERR_ROM As String * 4
Public LH1_ERR_WATCHDOG As String * 4
Public LH1_ERR_PWR_INT_TIMER As String * 4
'ERRSTAT2
Public LH1_ERR_DE_ICING As String * 4

'00 - OK, 01 - Always On, 10 - Always Off, 11 - ON
Public LH1_ERR_PROBE_HEATER As String * 10

Public LH1_MSO_Frequency As Float
Public LH1_ON_Time_Days As Float
Public LH1_Cold_Start_Count As Float
Public LH1_ICE_Count As Float
Public LH1_FAIL_Count As Float
Public LH1_MSO_FAIL_Count As Float
Public LH1_Heater_FAIL_Count As Float
Public LH1_Software_Version As Float
Public LH1_ICE_Count_From_PWR_ON As Float
Public LH1_CHECKSUM As Long
*****
'END - Public Variables for 0871LH1 RS-422 Output
*****

'Define Data Tables
'PLEASE NOTE: The majority of 0871LH1 outputs are diagnostic in nature. Add to Data Table(s)
' as required for your application.

DataTable (LH1_output,1,1000)
DataInterval (0,15,Sec,10)
Minimum (1,batt_volt,FP2,0,False)
Sample (1,PTemp,FP2)
Sample (1,Ice,IEEE4)
Sample (1,Ice_mm,IEEE4)
EndTable

'This Subroutine Sets all values to a Defaut Error State if Serial Communications do not work
Sub LH1_Error_State
LH1_Probe_Heater_State = "NAN"
LH1_Ice_Output = "NAN"
LH1_Status_Output = "NAN"
LH1_ERR_MSO_TOO_HIGH = "NAN"
LH1_ERR_MSO_TOO_LOW = "NAN"
LH1_ERR_EEPROM = "NAN"
LH1_ERR_RAM = "NAN"
LH1_ERR_ROM = "NAN"
LH1_ERR_WATCHDOG = "NAN"
LH1_ERR_PWR_INT_TIMER = "NAN"
LH1_ERR_DE_ICING = "NAN"
LH1_ERR_PROBE_HEATER = "NAN"

```

```

LH1_MSO_Frequency = NAN
LH1_ON_Time_Days = NAN
LH1_Cold_Start_Count = NAN
LH1_ICE_Count = NAN
LH1_FAIL_Count = NAN
LH1_MSO_FAIL_Count = NAN
LH1_Heater_FAIL_Count = NAN
LH1_Software_Version = NAN
LH1_ICE_Count_From_PWR_ON = NAN
LH1_CHECKSUM = NAN
EndSub

'*****
'o871LH1_GetData Subroutine (Typically Takes 3 Seconds to execute)
'*****

'Use an MD485 configured to RS-485, RS-232 Transparent Mode. 9600 BAUD for RS-232 and RS-485
Sub LH1_GetData
  Dim Stay_In_Loop As Boolean
  Dim CheckForBlankTime As Boolean
  Dim LoopCounter
  Dim Old_Byte_Count As Float
  Dim TimeSinceLastByte As Float
  Dim LH1_Raw_In_Buff As String * 50

  SerialFlush (LH1_comport)

  'Obtain the current byte count
  Old_Byte_Count = SerialInChk (LH1_comport)

  'Initializations reset and start the timer
  Timer (1,mSec,2)
  CheckForBlankTime = False
  LH1_Serial_Error = False
  Stay_In_Loop = True

  While Stay_In_Loop = True
    'Get the existing byte count
    LH1_Byte_Count = SerialInChk (LH1_comport)

    'reset the timer if the byte count is not the same
    If LH1_Byte_Count <> Old_Byte_Count Then

      'update the byte count
      Old_Byte_Count = LH1_Byte_Count

      'reset and start the timer
      Timer (1,mSec,2)

      'Received at least one byte start checking for a blank time
      CheckForBlankTime = True
    EndIf

    'Obtain the time from the last byte.
    TimeSinceLastByte = Timer (1,mSec,4)

    If CheckForBlankTime = True Then
      'If no characters occur within 100 msec of last byte then assume end of packet.
      If TimeSinceLastByte > 100 Then Stay_In_Loop = False
    EndIf

    'Exit regardless if more than 3 seconds elapse

```

```

If TimeSinceLastByte > 3000 Then
  LH1_Serial_Error = True
  Stay_In_Loop = False
EndIf

Wend

If LH1_Serial_Error = False Then
'Flush the buffer
SerialFlush (LH1_comport)

  'Wait a mximum of 2 seconds
  If Timer (2,mSec,4) > 2000 Then
    LH1_Serial_Error = TRUE
    Stay_In_Loop = False
  EndIf

Wend

'Obtain a CheckSum and convert All Binary Values
LH1_CHECKSUM = 0
'Convert all the BINARY Values
For LoopCounter=1 To 24 Step 1
  LH1_Byte(LoopCounter) = ASCII (LH1_Raw_In_Buff(1,1,LoopCounter))

  If LoopCounter <> 24
    LH1_CHECKSUM = LH1_CHECKSUM + LH1_Byte(LoopCounter)
  EndIf
Next
LH1_CHECKSUM = LH1_CHECKSUM AND &B11111111
If LH1_CHECKSUM <> LH1_Byte(LoopCounter) Then LH1_Serial_Error = TRUE
EndIf

If LH1_Serial_Error = TRUE Then
  Call LH1_Error_State
Else
'For LH1 Byte 1
'BIT 0 - Status Output
If (LH1_Byte(1) AND &B00000001) <> 0 Then
  LH1_Status_Output = "Fail"
Else
  LH1_Status_Output = "OK"
EndIf

```

```

'BIT 1 - Ice Output
If (LH1_Byte(1) AND &B00000010) <> 0 Then
  LH1_Ice_Output = "Ice"
Else
  LH1_Ice_Output = "No Ice"
EndIf

```

```

'BIT 2 - Probe Heater State
If (LH1_Byte(1) AND &B00000100) <> 0 Then
  LH1_Probe_Heater_State = "On"
Else
  LH1_Probe_Heater_State = "Off"
EndIf

```

```

'o871LH1 Bytes 2 and 3 are MSO Frequency count
'Calculate Frequency from the count as follows
LH1_MSO_Frequency = 774060000/((LH1_Byte(2) << 8) + LH1_Byte(3))

```

```

'Byte 4 is the ERRSTAT1
If (LH1_Byte(4) AND &B1) <> 0 Then
  LH1_ERR_PWR_INT_TIMER = "FAIL"
Else
  LH1_ERR_PWR_INT_TIMER = "OK"
EndIf

If (LH1_Byte(4) AND &B10) <> 0 Then
  LH1_ERR_WATCHDOG = "FAIL"
Else
  LH1_ERR_WATCHDOG = "OK"
EndIf

If (LH1_Byte(4) AND &B100) <> 0 Then
  LH1_ERR_ROM = "FAIL"
Else
  LH1_ERR_ROM = "OK"
EndIf

If (LH1_Byte(4) AND &B1000) <> 0 Then
  LH1_ERR_RAM = "FAIL"
Else
  LH1_ERR_RAM = "OK"
EndIf

If (LH1_Byte(4) AND &B10000) <> 0 Then
  LH1_ERR_EEPROM = "FAIL"
Else
  LH1_ERR_EEPROM = "OK"
EndIf

If (LH1_Byte(4) AND &B100000) <> 0 Then
  LH1_ERR_MSO_TOO_LOW = "FAIL"
Else
  LH1_ERR_MSO_TOO_LOW = "OK"
EndIf

If (LH1_Byte(4) AND &B1000000) <> 0 Then
  LH1_ERR_MSO_TOO_HIGH = "FAIL"
Else
  LH1_ERR_MSO_TOO_HIGH = "OK"
EndIf

If (LH1_Byte(5) AND &B011000000) = &B00000000 Then
  LH1_ERR_PROBE_HEATER = "OK"
Elseif (LH1_Byte(5) AND &B011000000) = &B01000000 Then
  LH1_ERR_PROBE_HEATER = "Always On"
Elseif (LH1_Byte(5) AND &B011000000) = &B10000000 Then
  LH1_ERR_PROBE_HEATER = "Always Off"
Elseif (LH1_Byte(5) AND &B011000000) = &B11000000 Then
  LH1_ERR_PROBE_HEATER = "On"
EndIf

If (LH1_Byte(5) AND &B001000000) <> 0 Then
  LH1_ERR_DE_ICING = "FAIL"
Else
  LH1_ERR_DE_ICING = "OK"
EndIf

'o871LH1 output ON time in 10 Minute Increments

```



```

LH1_ON_Time_Days = ((LH1_Byte(6) << 16) + (LH1_Byte(7) << 8) + LH1_Byte(8))/144
LH1_Cold_Start_Count = (LH1_Byte(9) << 8) + LH1_Byte(10)
LH1_ICE_Count = (LH1_Byte(11) << 8) + LH1_Byte(12)
LH1_FAIL_Count = LH1_Byte(13)
LH1_MSO_FAIL_Count = LH1_Byte(14)>>4
LH1_Heater_FAIL_Count = LH1_Byte(14) AND &B00001111
LH1_Software_Version = LH1_Byte(22)
LH1_ICE_Count_From_PWR_ON = LH1_Byte(23)

EndIf
EndSub

'Main Program
BeginProg

'Ensure that the proper Com port is defined for the Constant LH1_comport
SerialOpen (LH1_comport,9600,3,0,50)

Scan (15,Sec,0,0)
PanelTemp (PTemp,250)
Battery (batt_volt)
'Enter other measurement instructions

'Inteval Time for Reading the Ice Detector
If TimeInInterval(0,1,Min) Then Read_LH1 = True
Read_LH1 = True

If Read_LH1 = True Then
  Call LH1_GetData
  Read_LH1 = False
EndIf

'++++++
'NOTE: The use of the Ice thickness calculation is discretionary and dependant on the
' application. The maximum allowable ice is 0.02" before the heater turns on.

'Formula used to convert the Frequency into Ice Thickness (inches).
Ice = -0.00015*LH1_MSO_Frequency + 6
'Convert ice accumulation from inches to millimeters
Ice_mm = Ice * 25.4
'++++++

CallTable LH1_output
NextScan
EndProg

```

Appendix A. RS-422 Output Format

A.1 RS-422 Output Format for non-Campbell Datalogger Applications

This output operates at 9600 BAUD (One Start Bit, 8 Data Bits, No Parity, One Stop Bit). A 24-byte string is sent once per second. See Section 9, Table 3 for string definition.

A two-line output provides a unidirectional serial port, running at 9600 BAUD (8-bits, one Start Bit, One Stop Bit, no parity), to allow communication with aircraft electronics and external test equipment.

A.2 Built-In-Test (BIT)

Built-In-Test (BIT) capabilities of the freezing rain sensor consist of hardware, continuous, power-up, and operator-initiated tests.

Whenever a failure is detected and verified, the freezing rain sensor stops detecting and annunciating icing conditions and the heaters are disabled. Failures detected in Initiated and Continuous BIT are counted and enunciated once they have been verified. To eliminate nuisance errors, failures are verified by delaying (debouncing) the failure for a period of time. Failures detected in Initiated BIT are latched and power must be cycled on and off to remove a failure. If failures detected in Continuous BIT go away, the ice detector changes back to normal mode, and once again enables all ice detection functions.

A.3 Hardware Built-In-Test (BIT)

Hardware BIT is comprised of a watchdog timer that forces the microcontroller to re-initialize if it does not receive a strobe every 1.6 seconds. An internal voltage monitor forces the microcontroller to the reset state if the internal 5VDC power supply falls below 4.65 VDC and holds it there until the power supply returns above 4.65 VDC. When the microcontroller is reset, no output string is sent.

A.4 Continuous Built-In-Test (BIT)

Continuous BIT consists of verifying the following:

- The probe heater is in the correct state. The return leg of the heater is monitored.
- The ICE discrete output is in the correct state. The ICE discrete output is fed back to the microcontroller through a passive voltage divider and voltage comparator.
- The MSO is operating correctly. Frequencies between 39000 and 40150 Hz are valid.
- The probe heater is de-icing correctly. After turn-on, the probe heater must cause the MSO frequency to return to at least 39970 Hz within the 25 second timeout or it is considered failed.
- Probe is de-iced within 25 seconds. (De-Icing Fail).

A.5 BIT Failure That Disables Ice Output

The Ice output is disabled due to Continuous and Initiated BIT failures as shown in Table A-1. BIT Information. Ice detection is disabled when these failures occur because the integrity of the ice detection capability has been compromised.

Title	Disable Ice Detection ¹	Initiated BIT	Continuous BIT
MSO Fail, High	X		X
MSO Fail, Low	X		X
EEPROM Fail		X	
RAM Fail	X	X	
ROM Fail	X	X	
Watchdog Fail		X	
Power Interrupt Timer Fail		X	
Power Fault Monitor Fail		X	
Probe Heater Always ON or OPEN		Active Test	Passive Test
Probe Heater Always OFF		Active Test	Passive Test ²
Probe Heater ON w/ 1 Enable		X	
De-Icing Fail		Clear Only	Set Only
Unknown Reset Failure		X	

NOTEWhen the failure is enunciated, the software no longer provides ice detection capability.

NOTEIn Continuous BIT, the “Probe Heater Always OFF” failure is set when the heater is ON and a de-icing failure has been detected. If the frequency indicates that the ice has been removed within the expected time, the software will not annunciate the probe heater failure. The actual failure is most likely due to a problem in the heater feedback circuitry rather than heater control circuitry. The failure will be enunciated the next time IBIT is performed.

A.6 Operator-Initiated Tests

The operator can test the freezing rain sensor functionality by squeezing the tip of the probe between the index finger and thumb. This simulates icing by decreasing the frequency of the probe.

With the sensor wired to the datalogger use a digital voltmeter (DVM); measure DC voltage signal between the Ice signal (blue wire in control port) and the power reference ground (black wire in G terminal). The voltage reading should be 4500mVDC to 5000mVDC. When the probe tip of the ice detector is squeezed; thus changing the frequency and tripping the probe, the voltage reading will immediately drop to a reading below 500mVDC. Observing this will verify that the probe is operating properly and give the user enough time to release the probe before it reaches its full heating temperature.

CAUTION



Once initiated, the heating (de-icing) sequence will quickly heat the probe to 204.4°C. Though bare fingers must be used for a reliable test result, there is a danger that you will burn your fingers if you do not let go when heating has been verified.

A.7 Initiated Built-In-Test (BIT)

Initiated BIT is performed at initial power-up of the freezing rain sensor and following power interruptions of not less than 200 ms. Initiated BIT consists of the following tests:

- The ice and fault status outputs are set in the RS-422 string and on the discrete outputs so monitoring electronics or test equipment can verify activation.
- The freezing rain sensor heater is turned on for a short period of time to verify correct operation of the heater, heater control circuit, and heater feedback circuit.
- Correct operation of the watchdog timer is verified by simulating a microcontroller time-out and waiting for a reset input.

- Proper ROM operation is verified by computing a checksum of the ROM contents and comparing against a checksum stored in the ROM.
- RAM operation is verified by writing and reading test bytes.
- The Power Interrupt Timer is checked by verifying its transitions to a “warm” state after performing a “cold” start.
- The power fail input is pulled down to verify a power failure is detected.
- Each time the critical data from the Serial EEPROM is read, a checksum is read and compared to the checksum computed from the contents. Each time critical data is written to the Serial EEPROM, a checksum is computed and stored with the data.
- Resets due to unknown reasons (such as reset from the watchdog timer) are detected.

Initiated BIT will examine the RESET EEPROM input. If the input is active, the STATUS output will be set to FAIL and the ICE output and probe heater will be disabled. (This feature allows a factory technician to perform the MSO capacitor selection process without activation of the probe heater.)

Activation of the Press-to-Test (PTT) input for greater than 100 ms also causes the ice detector to perform Initiated BIT. The PTT input is ignored when the ice output is active. After PTT is completed, the correlation count is restored to its pre-test value.

Initiated BIT is complete within $3 \pm$ seconds of initial power up.

A.8 Correlation Counting

The freezing rain sensor tracks the amount of ice accumulation on the probe during an icing encounter. The correlation count is a value tracked by the freezing rain sensor that indicates the amount of ice that has accumulated on the probe during the icing encounter. Each correlation count equals 0.25 mm (0.01”) of ice.

The correlation count, ranging from 0 to 255, indicates the number of times the MSO frequency decreases by 65 Hz during an icing encounter. A decrease in frequency of 65 Hz correlates to an equivalent 0.25 mm of ice that would have formed on the ice detector probe, neglecting the change in collection efficiency caused by ice build-up. Upon reaching a correlation count of 255, the value is no longer incremented.

The freezing rain sensor compensates by adding a value (ranging from 0 to 6) to the correlation count when the ice detection cycle is completed, to account for the ice that would have accumulated if the heater had not been on.

The correlation count is in the serial string, Table A-2. Serial String Format.

The correlation count is initialized to zero at unit power up.

A.9 Ice Detector RS-422 String Format

Byte	Bit	Definition	Comments/Interpretation/Range
0 (First)	7 (MSB)	String ID	Presently defined as 00
	6		May add additional strings in future
	5 - 3	Unused	
	2	Probe Heater State	1- Heater On 0- Heater Off
	1	Ice Output	1- Ice 0- No Ice
	0	Status Output	1- Fail 0- (OK) No Fail
1 - 2 MSO FREQUENCY		MSO Count in Hex	Frequency = 774060000/Dec (MSO)
3 - ERRSTAT1	7	Unused	1 = Active
	6	MSA Fail, Too High	
	5	MSO Fail, Too Low	
	4	EEPROM Fail	
	3	RAM Fail	
	2	ROM Fail	
	1	Watchdog Fail	
	0	Power Interrupt Timer Fail	
4 - ERRSTAT2	7 - 6	Probe Heater Failure	00 = Probe Heater OK 01 = Probe Heater Always ON or OPEN 10 = Probe Heater Always OFF 11 = Probe Heater ON with 1 Enable
	5	De-Icing Fail	1 = Active
	4	Unused	
	3	Unused	
	2	Unused	
	1	Unused	
	0	Unused	
5 - 7 ON-TIME CNT		Power-On Time (In Hex) in 10-Minute Increments	00 - 01FFFF
8 - 9 COLD START CNT		Cold Start Power-On Count	00 - FFFF
10-11 ICE CNT		Ice Events	00 - FFFF
12 - FAIL CNT		Total Failures Encountered. This number is incremented each time the ice detector transitions from OK to fail.	00 - FF
13 - FAIL DTL 1	7 - 4 3 - 0	MSO Frequency Fail Count Heater Fail Count	0 - F 0 - F
14 - FAIL DTL 2	7 - 4 3 - 0	Not Used Not Used	Not Used Not Used
15 - LAST ERR 1		See ERRSTAT1 Above	

16 - LAST ERR 2		See ERRSTAT2 Above	
17 - 2ND LAST ERR 1		See ERRSTAT1 Above	
18 - 2ND LAST ERR 2		See ERRSTAT2 Above	
19 - PERM ERR 1		See ERRSTAT1 Above	
20 - PERM ERR 2		See ERRSTAT2 Above	
21 - Software Version	7 - 0	Software Version per VDD/SC1	0 - FF
22 - Correlation Count	7-0	0.01" ice accretion increments since power-on	0 - FF
23 - CHECKSUM		Summation (1-byte wide) of bytes 0 - 22	0 - FF

A.10 Electrostatic Discharge (ESD) Consideration

The freezing rain sensor internal components are ESD sensitive, class 1, so proper ESD precautions must be observed (wrist straps, conductive surfaces) when handling.

Appendix B. Freezing Rain Sensor

B.1 Freezing Rain Sensor Block Diagram

The block diagram in Figure B-1. Functional Block Diagram provides an understanding of the functionality of the freezing rain sensor.

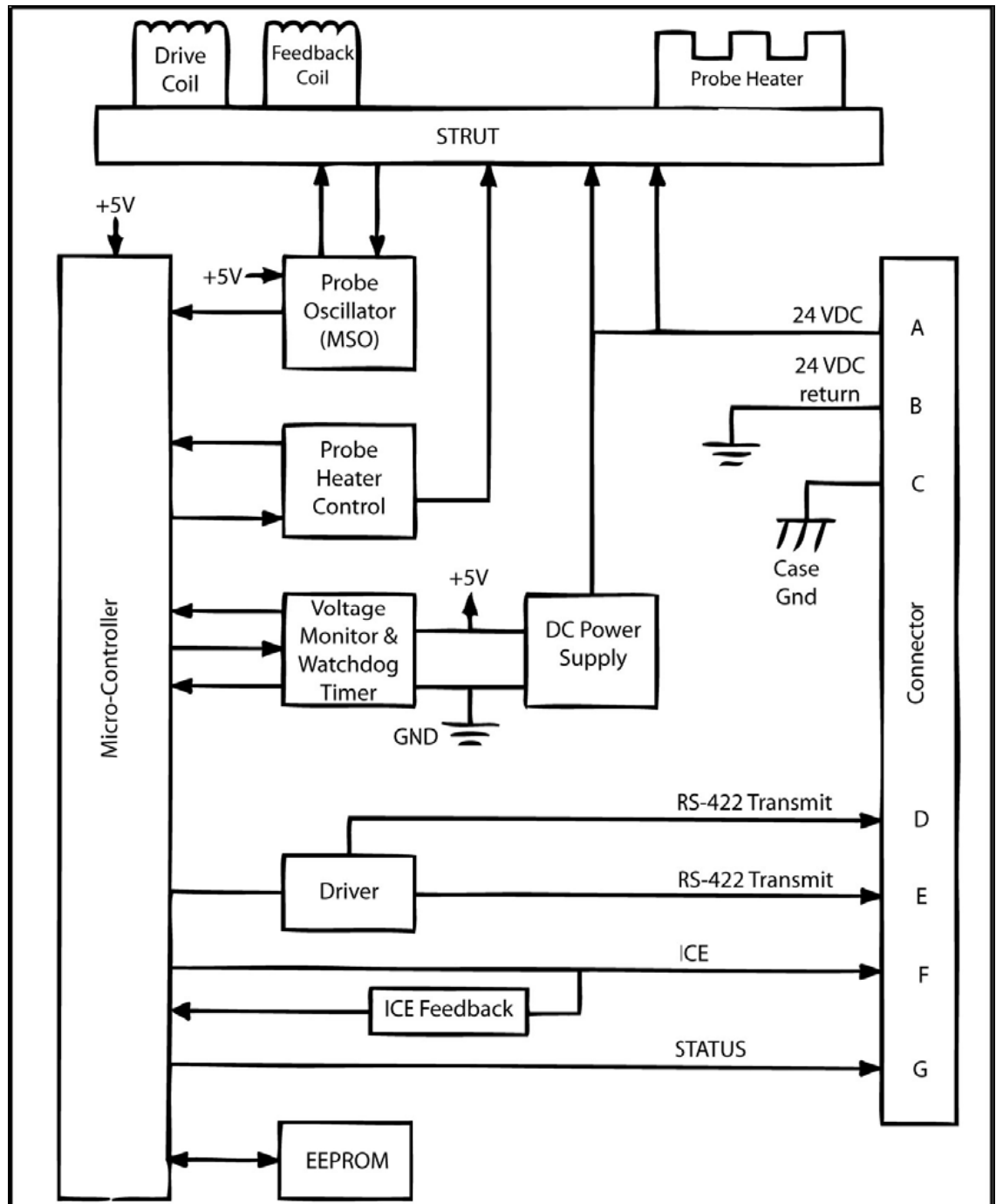

Figure B-1 Functional Block Diagram

B1.1 Microcontroller

The freezing rain sensor uses an Intel 87C51-type microcontroller to control the freezing rain sensor functions. This 8-bit microcontroller requires at least: 4 Kbytes of on-board ROM, 128 bytes of RAM, and 32 input/output ports. The freezing rain sensor uses about 75% of these resources. Upgraded microcontrollers that provide more resources are available. The microcontroller runs at 7.372 MHz.

B1.2 Watchdog/Reset Circuit

The watchdog timer/reset circuit monitors the microcontroller and provides a reset pulse if not periodically toggled. The watchdog also provides reset pulses on initial power-up and holds the microcontroller in the reset state if the internal power supply falls below an acceptable voltage. The watchdog indicates impending power loss so the ice detector can shut down in a known manner.

B1.3 Serial EEPROM

The Serial EEPROM stores unit status (icing state, failure state, heater state, correlation count) which is recovered after power interruptions of 200 ms or less. This allows the unit to meet the power interruption requirements of RTCA DC-160C, Section 16, Category Z. Additionally, the Serial EEPROM stores environmental and failure information such as unit elapsed-time, number of icing encounters, number of failures, and detailed information on types and quantities of each annunciated failure. This information is used by Rosemount Aerospace to confirm and repair failures reported by the end user and also to collect MTBF data. Each time the Serial EEPROM is written, a checksum is computed and written. Each time the Serial EEPROM is read, a checksum is computed and compared to the stored value.

B1.4 Probe Oscillator

The probe oscillator is the electronic control portion of the magnetostrictive oscillator (MSO) used to sense and detect ice. This circuit provides the drive and feedback of the ice sensing probe. The circuit drives the probe at a nominal 40kHz, and converts the feedback into a CMOS compatible square wave that is measured by the microcontroller. As ice accretes on the probe, the frequency decreases, and it is this frequency change that the microcontroller annunciates in the form of Ice Signal #1.

B1.5 Heater Control

The heater control turns the probe heater on and off as commanded by the microcontroller and monitors the actual heater state (ON or OFF) for verification by the microcontroller. Two outputs are required from the microcontroller to turn on the heater. This minimizes the possibility of an unintended heater ON condition. The heater control also monitors the state of the heater and provides feedback to the microcontroller so that it can be determined whether the heater is on or off.

B1.6 Drive Coil

The drive coil modulates the magnetic field of the magnetostrictive oscillator and causes an ultrasonic axial movement of the probe.

B1.7 Feedback Coil

The feedback coil senses the movement of the probe and when employed in the probe oscillator circuit, completes the feedback portion of the MSO.

B1.8 Heater

The probe heater de-ices the probe. It is activated when the nominal icing trip point of 0.50 mm is reached and is turned off five seconds after the MSO has returned to at least 39,970 Hz (the additional five seconds allows the strut probe time to shed the de-bonded ice). The maximum heater ON time is 25 seconds. If the probe frequency has not returned at least 39,970 Hz by that time, a de-ice failure is declared and the heaters are turned off. An open circuit of the heater is detected by the microcontroller.

B1.9 DC Power Supply

The DC power supply provides 24 VDC for the heater circuitry. Internal circuitry converts the 24 VDC input power to 5 VDC for use by the microcontroller and associated circuits. It employs a large input capacitor to provide enough time between detection of input power loss and actual loss of DC power, for the microcontroller to store the current unity status in the non-volatile memory. The DC power supply provides input transient protection to meet RTCA DO-160C power input, voltage spike, and lightning requirements.

B1.10 Status Output

The status output provides a ground output when the freezing rain sensor is operating correctly, and high impedance (200 K Ω minimum) when the unit has detected a failure. Failures are detected through continuous and initiated tests. The Status output is capable of sinking 50 mA and is guaranteed to be no more than 1.5 VDC with respect to Signal Return when active. This output is transient protected to meet RTCA DO-160C lightning requirements and to prevent stray high-voltage from coupling into the unit and damaging the output transistor.

B1.11 Ice Signal Output

The Ice Signal output provides a ground output for 60 ± 6 seconds when the ice detector has detected the presence of ice (frequency drop of 130 Hz, equivalent to approximately 0.50 mm ice formation). If the frequency subsequently decreases by 130 Hz while the Ice Signal output timer is non-zero, the timer is reinitialized to 60 seconds.

The output is transient protected to meet RTCA DO-160C lightning requirements and to prevent stray high-voltage from coupling into the unit and damaging the output transistor.

The ice output has feedback to the microcontroller for software to verify it is in the correct state for more built in test coverage. The software in the 0871KB2 model uses this feedback to verify that the ice output is operating correctly.

To interface to the 0871LH1, the power supply must provide a pull-up of 5.3 volts maximum. When the ice output is inactive (open), the nominal resistance to ground is 10.1 KΩ. The power supply should source at least 0.250 mA to provide the proper signal to the Ice Signal feedback circuitry. When the output is active (closed), it is capable of sinking 50 mA and is guaranteed to be no more than 1.5 VDC with respect to Signal Return.

B.2 Qualification Capabilities

Table B-1 0871LH1 Ice Detector Qualification Capabilities

Test Name	Test Requirement	
EMC	DO-160C:	
	Audio Freq Susc:	Cat Z
	Induced Signal:	Cat Z
	Susc:	Chg Notice 3, Cat R
	RF Susceptibility:	Cat Z
	RF Emissions:	Cat Z
Lightning Induced Susceptibility	DO-160C:	
	Multiple Burst:	Waveform 3 & 4: Level 3
	Multiple Stroke:	Waveform 3: Level 3
Temperature Variation	DO-160C:	Cat A
Temperature/Altitude	DO-160C:	Cat D2 (-40°C to +71°C)
Vibration	DO-160C:	Cat E (Random, 7.9 grms)
Operation Shock, Crash Safety	DO-160C:	Shock
Salt Spray	DO-160C:	Cat S
Humidity	DO-160C:	Cat B
Icing Performance	Rosemount Aerospace, Inc. Test Procedure	
Power Input	DO-160C:	Cat Z, 18 - 29.5 VDC
Voltage Spike	DO-160C:	Cat A
Magnetic Effect	DO-160C:	Cat A (1 deflection at 0.5m)
Bonding	2.5 mW Max. Mounting Plate to Aircraft Structure	
	10 mW Max. Connector Shell to Mounting Plate	
Dielectric Withstanding	MIL-STD 202, 500 VAC, 60 Hz, EMI Filters Disconnected	
Insulation Resistance	MIL-STD 202, 500 VDC, 1000 MW, EMI Filters Disconnected	
Fluid Susceptibility	DO-160C:	Cat F
Waterproofness	DO-160C:	Cat W
Fungus Resistance	DO-160C:	Cat F
Sand and Dust	DO-160C:	Cat D
Direct Lightning Strike	DO-160C:	Cat 1A
Software	DO-178B used as a guideline	

B.3 Input/Output Specification

B3.1 Input/Output Pin Designations

Table B-2 Input/Output Pin Designations					
Signal Name	Connector Pin	Input or Output	Definition	Current	Wire Gauge
24VDC	A	Input	18-29.5 VDC**	1.5 Amp Max at 28VDC	20
24VDC Return	B	Input	----	----	20
Case Ground	C	Input	----	----	20
RS-422 High	D	Output	Per RS-422 Spec	Per RS-422 Spec	20-24
RS-422 Low	E	Output	Per RS-422 Spec	Per RS-422 Spec	20-24
Ice	F	Output	Ground Active (1.5V Max) Open Inactive	0.5 - 50 mA	20-24
Status	G	Output	Ground Active (1.5V Max) Open Active	0.5 - 50 mA	20-24

**Ice will be correctly detected between these voltages. Proper probe de-icing, however, is only guaranteed when input voltage is 24VDC or greater.

CAMPBELL SCIENTIFIC COMPANIES

Campbell Scientific, Inc. (CSI)

815 West 1800 North
Logan, Utah 84321
UNITED STATES

www.campbellsci.com • info@campbellsci.com

Campbell Scientific Africa Pty. Ltd. (CSAf)

PO Box 2450
Somerset West 7129
SOUTH AFRICA

www.csafrica.co.za • sales@csafrica.co.za

Campbell Scientific Australia Pty. Ltd. (CSA)

PO Box 8108
Garbutt Post Shop
QLD 4814 AUSTRALIA

www.campbellsci.com.au • info@campbellsci.com.au

Campbell Scientific do Brazil Ltda. (CSB)

Rua Luisa Crapsi Orsi, 15 Butantã
CEP: 005543-000 São Paulo SP BRAZIL

www.campbellsci.com.br • suporte@campbellsci.com.br

Campbell Scientific Canada Corp. (CSC)

11564 - 149th Street NW
Edmonton, Alberta T5M 1W7
CANADA

www.campbellsci.ca • dataloggers@campbellsci.ca

Campbell Scientific Centro Caribe S.A. (CSCC)

300N Cementerio, Edificio Breller
Santo Domingo, Heredia 40305
COSTA RICA

www.campbellsci.cc • info@campbellsci.cc

Campbell Scientific Ltd. (CSL)

Campbell Park
80 Hathern Road
Shepshed, Loughborough LE12 9GX
UNITED KINGDOM

www.campbellsci.co.uk • sales@campbellsci.co.uk

Campbell Scientific Ltd. (France)

3 Avenue de la Division Leclerc
92160 ANTONY
FRANCE

www.campbellsci.fr • info@campbellsci.fr

Campbell Scientific Spain, S. L.

Avda. Pompeu Fabra 7-9
Local 1 - 08024 BARCELONA
SPAIN

www.campbellsci.es • info@campbellsci.es

Campbell Scientific Ltd. (Germany)

Fahrenheitstrasse13, D-28359 Bremen
GERMANY

www.campbellsci.de • info@campbellsci.de